

Magnetically Coupled Rodless Cylinder Basic Type

ø6, ø10, ø15, ø20, ø25, ø32, ø40, ø50, ø63

New

RoHS

Lightweight.....

The product weight has been reduced through re-designing of the body and head cover shapes and employment of magnetic coupling.

Weight

16% reduction

1.35 kg → 1.13 kg

Compared with the existing CY3B series model,
ø32, 100 mm stroke

Head cover

Body

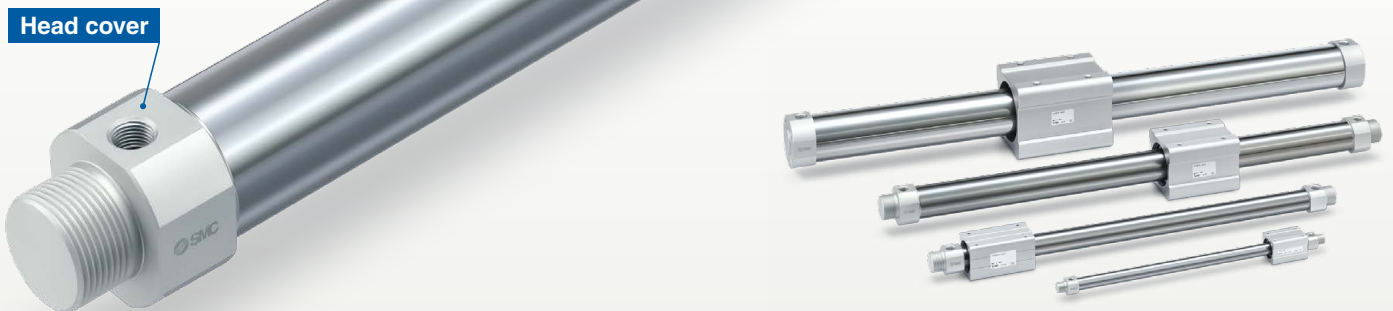

Improved lubrication.....

A **Lube-retainer** is installed to support lubrication retention on the piston and to ensure a lubrication film. (Bore size: ø15 to ø63)

Stable operation.....

Lengthening of the **wear ring** on the body side by, 30% at maximum, helps to achieve smooth movement.

■ The specifications, magnet holding force, and mounting dimensions are the same as those of the existing CY3B series model.

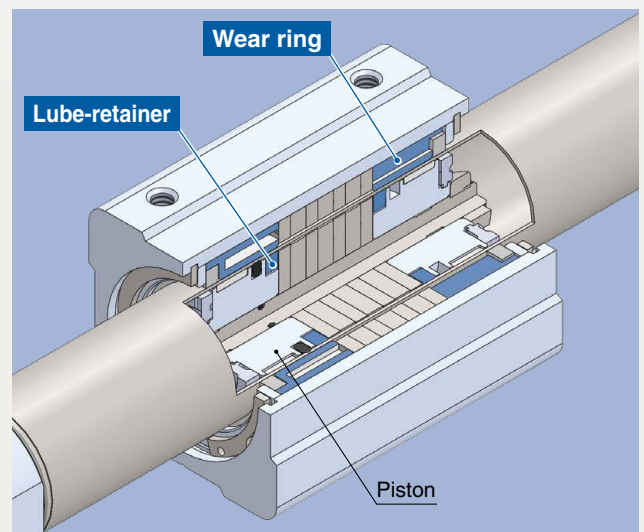

CY3B Series



CAT.ES20-277A

Magnetically Coupled Rodless Cylinder/ Basic Type *CY3B Series*

Series Variations

| Series | Bore size | Standard stroke [mm] | | | | | | | | | | | | | | Piston speed | Cushion | Mounting orientation | Magnet holding force | | | | | | | |
|--|-----------|----------------------|-----|-----|-----|-----|-----|-----|-----|-----|-----|-----|-----|-----|-----|--------------|---------|----------------------|----------------------|---------------|------------------------------------|--------|--------|-------|-------|--------|
| | | 50 | 100 | 150 | 200 | 250 | 300 | 350 | 400 | 450 | 500 | 600 | 700 | 800 | 900 | | | | | 1000 | | | | | | |
|  Basic type | 6 | ● | ● | ● | ● | | | | | | | | | | | | | | 50 to 500 mm/s | Rubber bumper | Horizontal Inclined Vertical | 19.6 N | | | | |
| | 10 | ● | ● | ● | ● | ● | ● | | | | | | | | | | | | | | | | 53.9 N | | | |
| | 15 | ● | ● | ● | ● | ● | ● | ● | ● | ● | ● | | | | | | | | | | | | | 137 N | | |
| | 20 | ● | ● | ● | ● | ● | ● | ● | ● | ● | ● | ● | ● | ● | ● | ● | | | | | | | | 231 N | | |
| | 25 | ● | ● | ● | ● | ● | ● | ● | ● | ● | ● | ● | ● | ● | ● | ● | ● | ● | ● | | | ● | | | 363 N | |
| | 32 | ● | ● | ● | ● | ● | ● | ● | ● | ● | ● | ● | ● | ● | ● | ● | ● | ● | ● | | | ● | ● | | | 588 N |
| | 40 | ● | ● | ● | ● | ● | ● | ● | ● | ● | ● | ● | ● | ● | ● | ● | ● | ● | ● | | | ● | ● | ● | ● | 922 N |
| | 50 | ● | ● | ● | ● | ● | ● | ● | ● | ● | ● | ● | ● | ● | ● | ● | ● | ● | ● | | | ● | ● | ● | ● | 1471 N |
| 63 | ● | ● | ● | ● | ● | ● | ● | ● | ● | ● | ● | ● | ● | ● | ● | ● | ● | ● | ● | ● | ● | ● | 2256 N | | | |



CONTENTS

| | |
|------------------------------------|------|
| Model Selection | p. 2 |
| How to Order | p. 6 |
| Specifications | p. 6 |
| Dimensions | p. 8 |
| Specific Product Precautions | p. 9 |

CY3B Series Model Selection

E: Kinetic energy of load [J]

$$E = \frac{(W + W_b)}{2} \times \left(\frac{V}{1000}\right)^2$$

Es: Allowable kinetic energy for intermediate stop using an air pressure circuit [J]

Fn: Allowable driving force [N]

Mb: Max. allowable moment when a connection bracket, etc., is carried directly [N·m]

Ps: Operating pressure limit for intermediate stop using an external stopper, etc. [MPa]

Pv: Max. operating pressure for vertical operation [MPa]

Wbmax: Max. load mass when loaded directly on the body [kg]

Wv: Allowable load mass for vertical operation [kg]

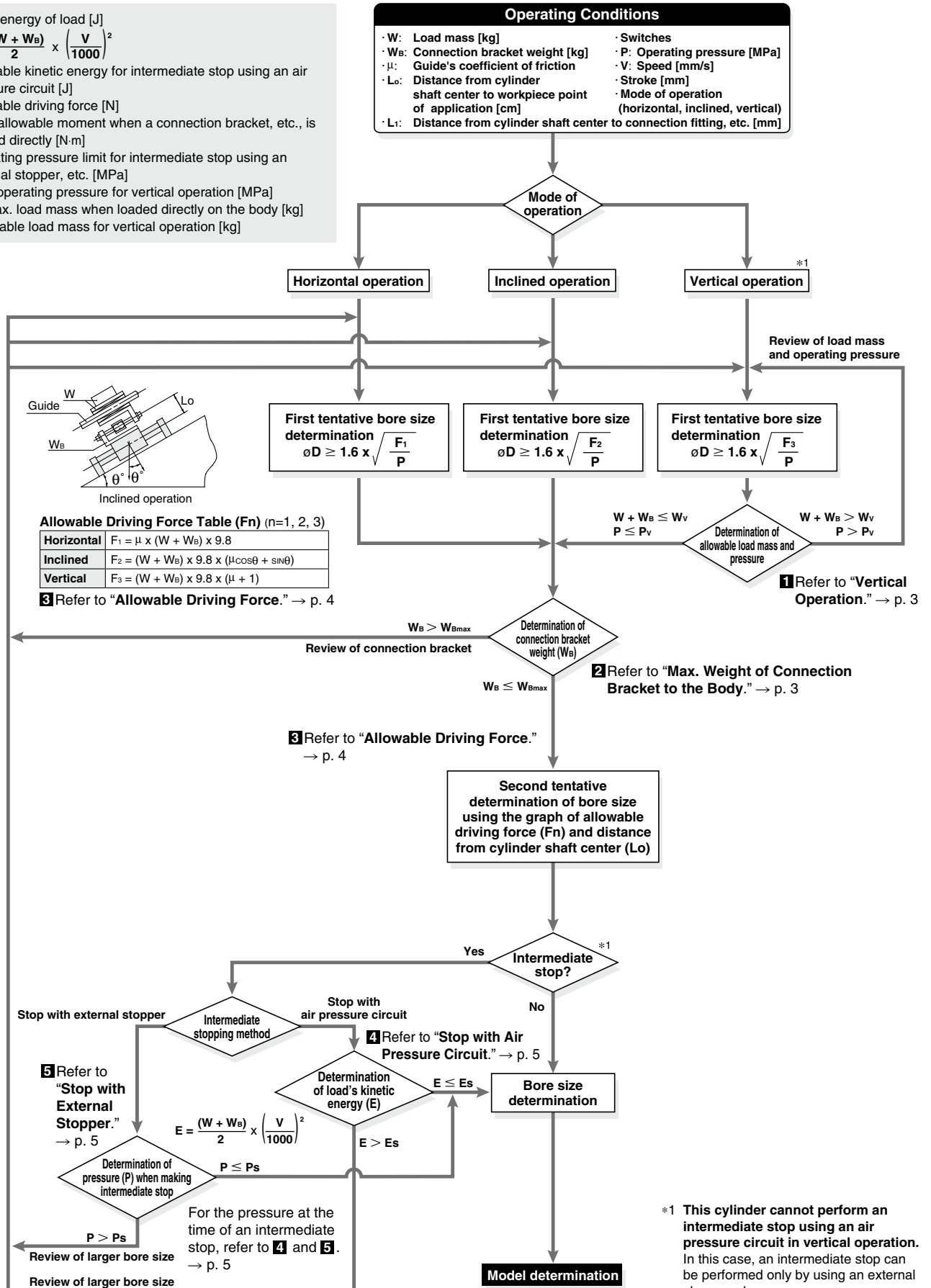

CY3B Series

1 Vertical Operation

It is recommended that the load is guided by a ball type bearing (linear guide, etc.). If a slide bearing is used, sliding resistance increases due to the load mass and moment, which may cause malfunctions.

When the cylinder is mounted vertically or on an angle, be sure to use an external stopper, etc., for positioning.

In addition, as the slider may move downward toward the stroke end due to its self-weight or the mass of the workpiece, use an external stopper, etc., for positioning if accurate positioning is required.

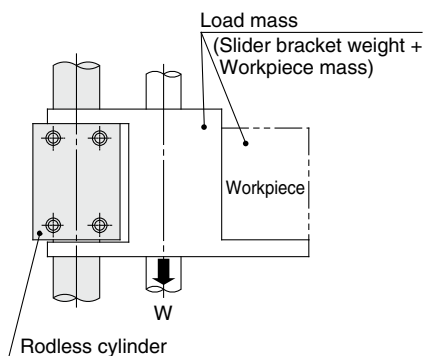

| Bore size [mm] | Model | Allowable load mass (Wv) [kg] | Max. operating pressure (Pv) [MPa] |
|----------------|--------|-------------------------------|------------------------------------|
| 6 | CY3B6 | 1.0 | 0.55 |
| 10 | CY3B10 | 2.7 | 0.55 |
| 15 | CY3B15 | 7.0 | 0.65 |
| 20 | CY3B20 | 11.0 | 0.65 |
| 25 | CY3B25 | 18.5 | 0.65 |
| 32 | CY3B32 | 30.0 | 0.65 |
| 40 | CY3B40 | 47.0 | 0.65 |
| 50 | CY3B50 | 75.0 | 0.65 |
| 63 | CY3B63 | 115.0 | 0.65 |

* Use caution, as there is a danger of breaking the magnetic coupling if operated above the max. operating pressure.

Cylinder Self-Weight Deflection

When the cylinder is mounted horizontally, deflection appears due to its self-weight as shown in the data, and the longer the stroke is, the greater the amount of variation in the shaft center. Therefore, a connection method should be considered which can assimilate this deflection.

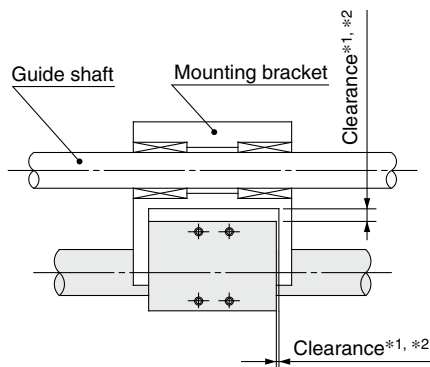

*1 According to the self-weight deflection in the figure on the right, provide clearance so that the cylinder does not touch the mounting surface or the load, etc., and is able to operate smoothly within the min. operating pressure range for a full stroke. For more information, refer to the Operation Manual.

*2 The amount of deflection differs from the CY1B. Adjust the clearance value by referring to the self-weight deflection as shown in the table on the right.

When the CY1B is replaced with the CY3B, install a cylinder after confirming a full stroke and clearance are allowed.

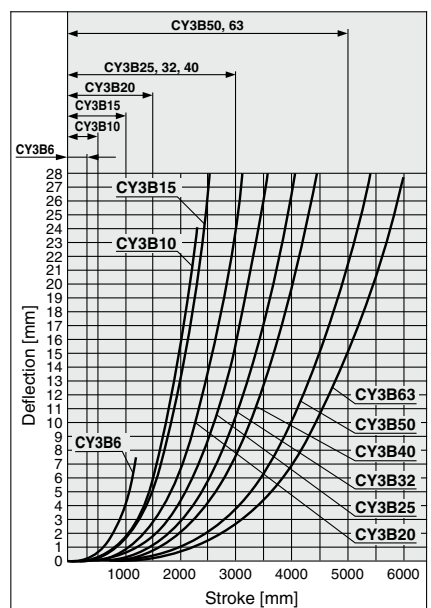
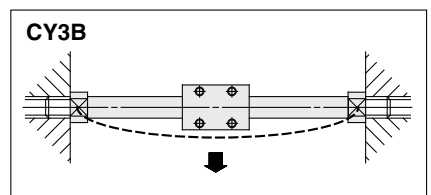

* The above deflection data represent values at the time when the external sliding part moves to the middle of the stroke.

2 Max. Weight of Connection Bracket to the Body

The CY3B series is guided by an external axis (such as a linear guide) without directly mounting the load. When designing a metal bracket to connect the load, make sure that its weight will not exceed the value in the table on the right.

(For connection methods, refer to the Operation Manual.)

Max. Connection Bracket Weight

| Model | Max. connection bracket weight (W _{max}) [kg] |
|--------|---|
| CY3B6 | 0.2 |
| CY3B10 | 0.4 |
| CY3B15 | 1.0 |
| CY3B20 | 1.1 |
| CY3B25 | 1.2 |
| CY3B32 | 1.5 |
| CY3B40 | 2.0 |
| CY3B50 | 2.5 |
| CY3B63 | 3.0 |

3 Allowable Driving Force

Selection procedure

1. Find the drive resisting force F_n [N] when moving the load horizontally.
2. Find the distance L_o [cm] from the point of the load where driving force is applied, to the center of the cylinder shaft.
3. Select the bore size from L_o and F_n , based on data (A).

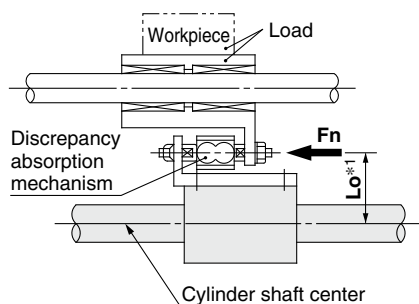

Selection example

Given a load drive resisting force of $F_n = 100$ [N] and a distance from the cylinder shaft center to the load application point of $L_o = 8$ cm, find the intersection point by extending upward from the horizontal axis of data (A) where the distance from the shaft center is 8 cm, and then extending to the side, find the allowable driving force on the vertical axis.

Models suitable in satisfying the requirement of 100 [N] are the **CY3B32** or **CY3B40**.

*1 The L_o point from the cylinder shaft center is the moment working point between the cylinder and the load section.

<Data (A) : Distance from cylinder shaft center — Allowable driving force>

CY3B6

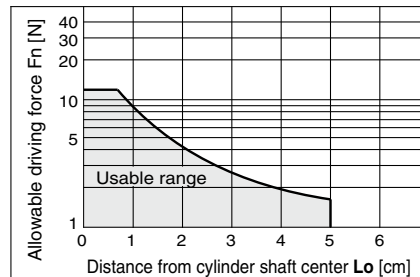

CY3B32

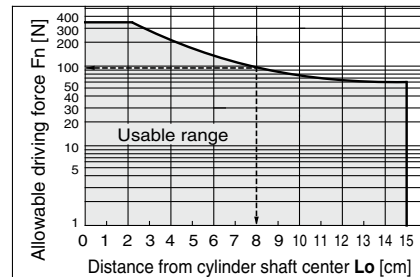

CY3B10

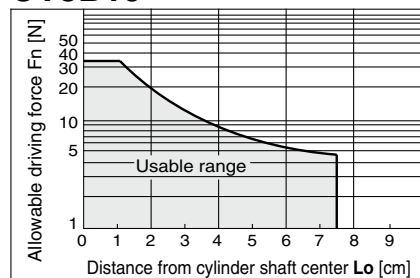

CY3B40

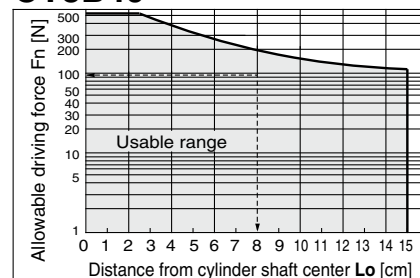

CY3B15

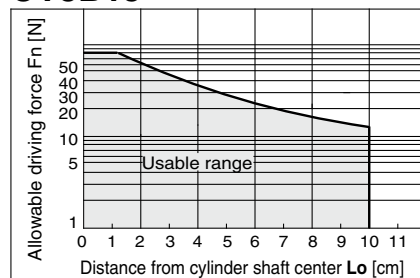

CY3B50

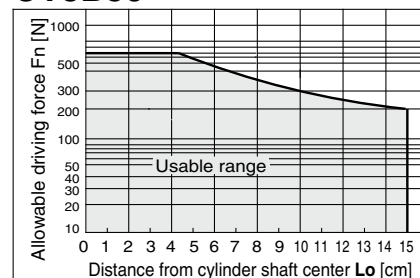

CY3B20

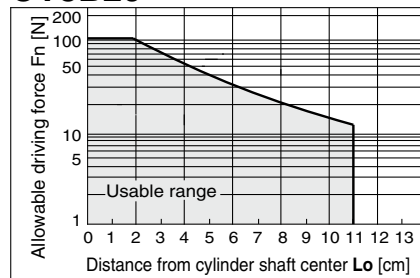

CY3B63

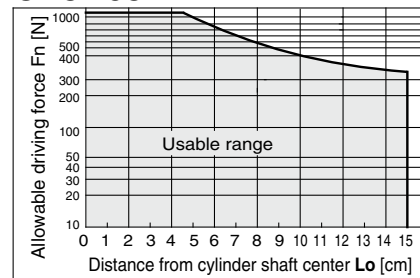

CY3B25

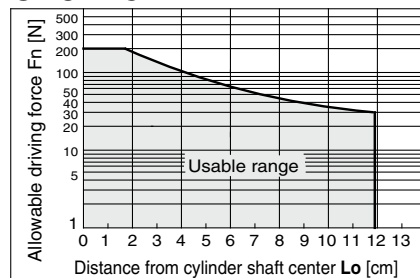

Intermediate Stop

4 Stop with Air Pressure Circuit

When performing an intermediate stop of a load using an air pressure circuit, operate at or below the kinetic energy shown in the table on the right. Use caution, as operation when exceeding the allowable value can result in breaking of the magnetic coupling.

When the cylinder is operated at full stroke without an external stopper, a similar condition may result. Therefore, use the product with the kinetic energy shown in the table on the right or below.

When an intermediate stop is performed by means of an air pressure circuit, the body stopping accuracy is not high. If a high stopping accuracy is required, consider positioning with an external stopper.

For vertical actuation, intermediate stop with a pneumatic circuit is not possible. In this case as well, consider the intermediate stop method using an external stopper.

(Reference values)

| Bore size [mm] | Model | Allowable kinetic energy for intermediate stop (Es) [J] |
|----------------|--------|---|
| 6 | CY3B6 | 0.007 |
| 10 | CY3B10 | 0.03 |
| 15 | CY3B15 | 0.13 |
| 20 | CY3B20 | 0.24 |
| 25 | CY3B25 | 0.45 |
| 32 | CY3B32 | 0.88 |
| 40 | CY3B40 | 1.53 |
| 50 | CY3B50 | 3.12 |
| 63 | CY3B63 | 5.07 |

5 Stop with External Stopper

Intermediate stopping of load with an external stopper, etc.

When stopping a load in mid-stroke using an external stopper, etc., operate within the operating pressure limits shown in the table on the right. Use caution, as operation at a pressure exceeding these limits can result in breaking of the magnetic coupling.

| Bore size [mm] | Model | Operating pressure limit for intermediate stop (Ps) [MPa] |
|----------------|--------|---|
| 6 | CY3B6 | 0.55 |
| 10 | CY3B10 | 0.55 |
| 15 | CY3B15 | 0.65 |
| 20 | CY3B20 | 0.65 |
| 25 | CY3B25 | 0.65 |
| 32 | CY3B32 | 0.65 |
| 40 | CY3B40 | 0.65 |
| 50 | CY3B50 | 0.65 |
| 63 | CY3B63 | 0.65 |

Stroke End Stopping Method

When stopping a load having a large inertial force at the stroke end, tilting of the body and damage to the bearings and cylinder tube may occur. (Refer to Fig. 1.)

As shown in Fig. 2, a shock absorber should be used together with the stopper, and thrust should also be transmitted from the center of the body so that tilting will not occur.

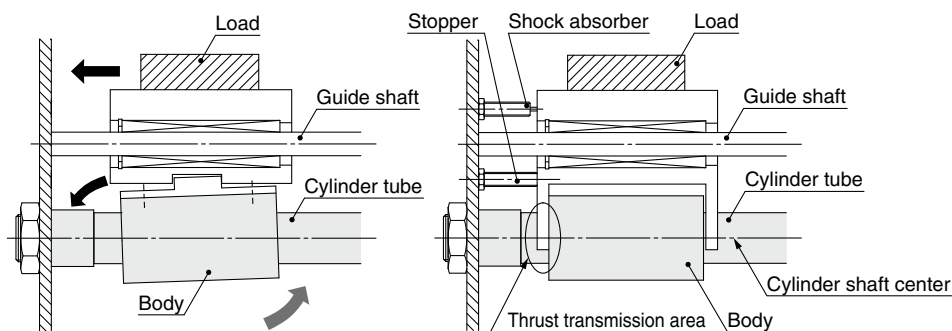

Fig. 1

Fig. 2

Magnetically Coupled Rodless Cylinder Basic Type

CY3B Series

∅6, ∅10, ∅15, ∅20, ∅25, ∅32, ∅40, ∅50, ∅63

How to Order



Basic type

CY3B 25 - **300 Z**

Basic type

Standard stroke

Refer to the standard stroke table shown below.

Bore size

| | |
|----|-------|
| 6 | 6 mm |
| 10 | 10 mm |
| 15 | 15 mm |
| 20 | 20 mm |
| 25 | 25 mm |
| 32 | 32 mm |
| 40 | 40 mm |
| 50 | 50 mm |
| 63 | 63 mm |

Port thread type

| Symbol | Type | Bore size |
|--------|----------|---------------------------|
| Nil | M thread | 6, 10, 15 |
| | Rc | 20, 25, 32, 40, 50, 63 |
| TN | NPT | |
| TF | G | |

Standard Strokes

| Bore size [mm] | Standard stroke [mm] | Manufacturable stroke [mm] |
|----------------|---|----------------------------|
| 6 | 50, 100, 150, 200 | 20 to 300 |
| 10 | 50, 100, 150, 200, 250, 300 | 20 to 500 |
| 15 | 50, 100, 150, 200, 250, 300, 350, 400, 450, 500 | 20 to 1000 |
| 20 | 100, 150, 200, 250, 300, 350, 400, 450, 500, 600, 700, 800 | 25 to 1500 |
| 25 | | 25 to 3000 |
| 32 | 100, 150, 200, 250, 300, 350, 400, 450, 500, 600, 700, 800, 900, 1000 | 25 to 3000 |
| 40 | | 25 to 3000 |
| 50 | | 40 to 5000 |
| 63 | | 40 to 5000 |

* Long stroke type (XB11) applies to the strokes exceeding 2000 mm.

* The longer the stroke, the larger the amount of deflection in a cylinder tube. Pay attention to the mounting bracket and clearance value.

* Intermediate stroke is available in 1 mm increments.

Symbol

Rubber bumper (Magnet type)

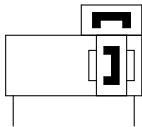

Made to Order
[Click here for details](#)

| Symbol | Specifications |
|--------|--|
| -XB6 | Head resistant cylinder (-10 to 150°C) |
| -XB9 | Low-speed cylinder (15 to 50 mm/s) |
| -XB11 | Long stroke type |
| -XB13 | Low-speed cylinder (7 to 50 mm/s) |
| -XC24 | With magnetic shielding plate |
| -XC57 | With floating joint |

For clean specifications, refer to the [Web Catalog](#).



Made to Order: Individual Specifications
(For details, refer to pages 8-1 to 8-3.)

| Symbol | Specifications |
|--------|---|
| -X116 | Hydro specifications |
| -X132 | Air supply port relocated in axial direction |
| -X160 | High speed specifications |
| -X168 | Helical insert thread specifications |
| -X206 | Added mounting tap positions for slider |
| -X210 | Non-lubricated exterior specifications |
| -X322 | Outside of cylinder tube with hard chrome plated |
| -X324 | Non-lubricated exterior specifications (with dust seal) |

Specifications

| Bore size [mm] | 6 | 10 | 15 | 20 | 25 | 32 | 40 | 50 | 63 |
|--------------------------------|---|------|------|------|------|------|------|------|------|
| Fluid | Air | | | | | | | | |
| Proof pressure | 1.05 MPa | | | | | | | | |
| Max. operating pressure*1 | 0.7 MPa | | | | | | | | |
| Min. operating pressure | 0.16 | 0.16 | 0.16 | 0.16 | 0.15 | 0.14 | 0.12 | 0.12 | 0.12 |
| Ambient and fluid temperatures | -10 to 60°C (No freezing) | | | | | | | | |
| Piston speed | 50 to 500 mm/s | | | | | | | | |
| Cushion | Rubber bumper | | | | | | | | |
| Lubrication | Not required (Non-lube) | | | | | | | | |
| Stroke length tolerance [mm] | 0 to 250 st: $^{+1.0}_0$, 251 to 1000 st: $^{+1.4}_0$, 1001 st or more: $^{+1.8}_0$ | | | | | | | | |
| Mounting orientation | Horizontal, Inclined, Vertical | | | | | | | | |
| Mounting nut (2 pcs.) | Standard equipment (Accessory) | | | | | | | | |
| Magnet holding force [N] | 19.6 | 53.9 | 137 | 231 | 363 | 588 | 922 | 1471 | 2256 |

*1 Note that to perform an intermediate stop with an external stopper, the required operating pressure limit is the pressure explained in "Stop with External Stopper" on page 5.

CY3B Series

Theoretical Cylinder Thrust

Caution When calculating the actual thrust, design should consider the min. operating pressure.

ø6, ø10

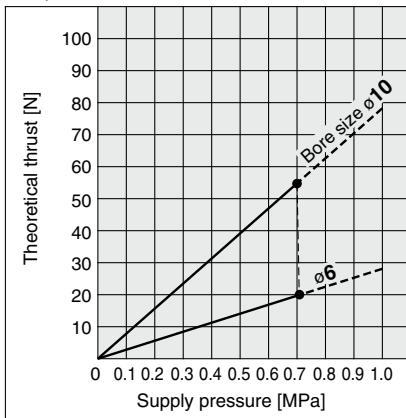

ø15, ø20, ø25, ø32, ø40

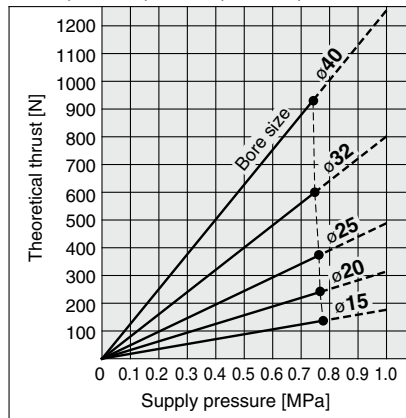

ø50, ø63

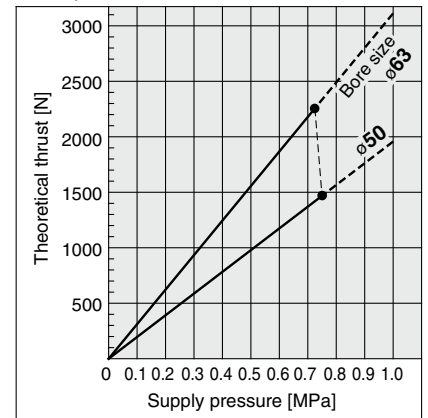

Weight

Unit: kg

| Bore size [mm] | 6 | 10 | 15 | 20 | 25 | 32 | 40 | 50 | 63 |
|---------------------------------------|-------|-------|-------|-------|-------|-------|-------|-------|-------|
| Basic weight (at 0 st) | 0.039 | 0.080 | 0.228 | 0.344 | 0.591 | 1.06 | 1.80 | 3.04 | 4.70 |
| Additional weight per 50 mm of stroke | 0.004 | 0.014 | 0.015 | 0.020 | 0.023 | 0.033 | 0.040 | 0.077 | 0.096 |

Calculation method/Example: **CY3B32-500Z** Basic weight 1.06 kg
 Additional weight 0.033/50 st } 1.06 + 0.033 x 500 ÷ 50 = 1.39 kg
 Cylinder stroke 500 st

Replacement Parts: Seal Kit

CY3B6, 10-□Z

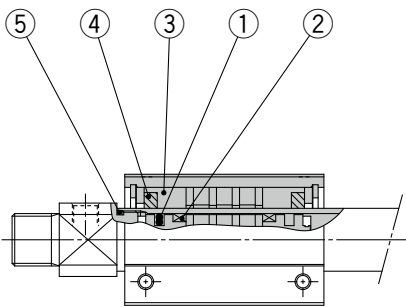

CY3B15 to 40-□Z

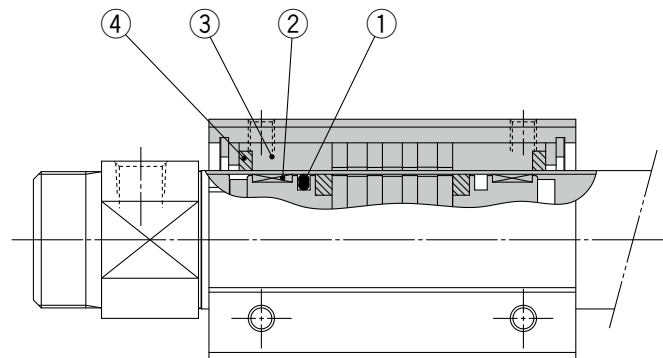

Component Parts

| No. | Description |
|-----|----------------------|
| 1 | Piston seal |
| 2 | Wear ring A |
| 3 | Wear ring B |
| 4 | Lube-retainer B |
| 5 | Cylinder tube gasket |

Seal Kit/Part Nos.

| Bore size [mm] | Part no. | Contents |
|----------------|-------------|--|
| 6 | CY3B6-Z-PS | ① (2 pcs.), ② (4 pcs.), ③ (2 pcs.), ⑤ (2 pcs.) |
| 10 | CY3B10-Z-PS | ① (1 pc.), ③ (2 pcs.), ④ (2 pcs.), ⑤ (2 pcs.) |
| 15 | CY3B15-Z-PS | ① (1 pc.), ② (4 pcs.), ③ (2 pcs.), ④ (2 pcs.) |
| 20 | CY3B20-Z-PS | ① (1 pc.), ② (2 pcs.), ③ (2 pcs.), ④ (2 pcs.) |
| 25 | CY3B25-Z-PS | |
| 32 | CY3B32-Z-PS | |
| 40 | CY3B40-Z-PS | |

* As sizes ø50 and ø63 cannot be disassembled, the seal kit cannot be replaced.

* The seal kit includes a grease pack (10 g).

Order with the following part number when only the grease pack is required.

Grease pack part number: GR-S-010

* For replacement of the ø10 wear ring A, please contact SMC.

Dimensions

CY3B6 to 15-□Z

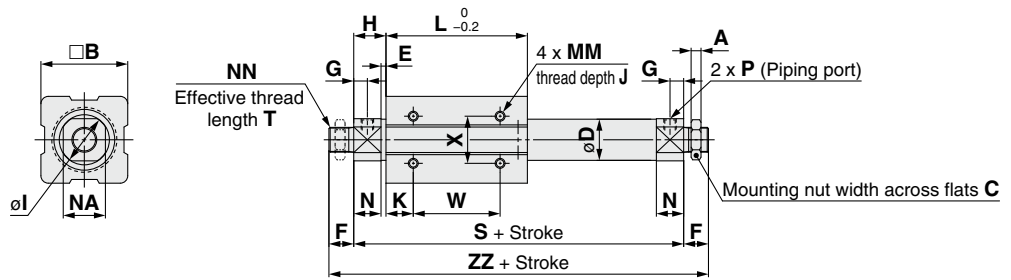

CY3B20 to 40-□Z

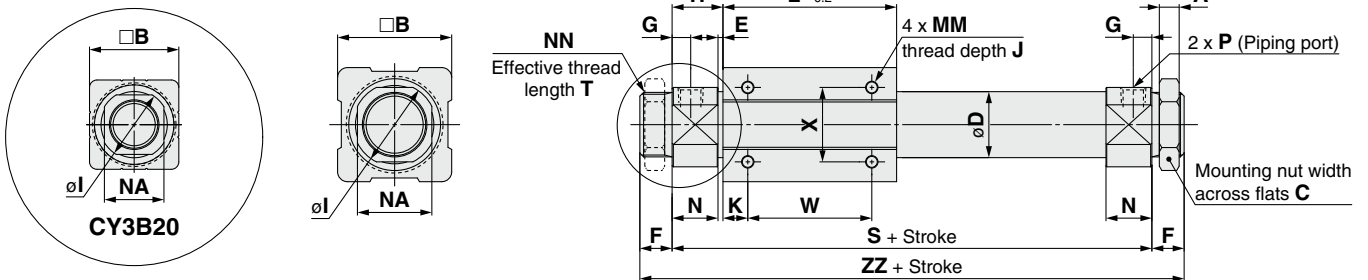

CY3B50, 63-□Z

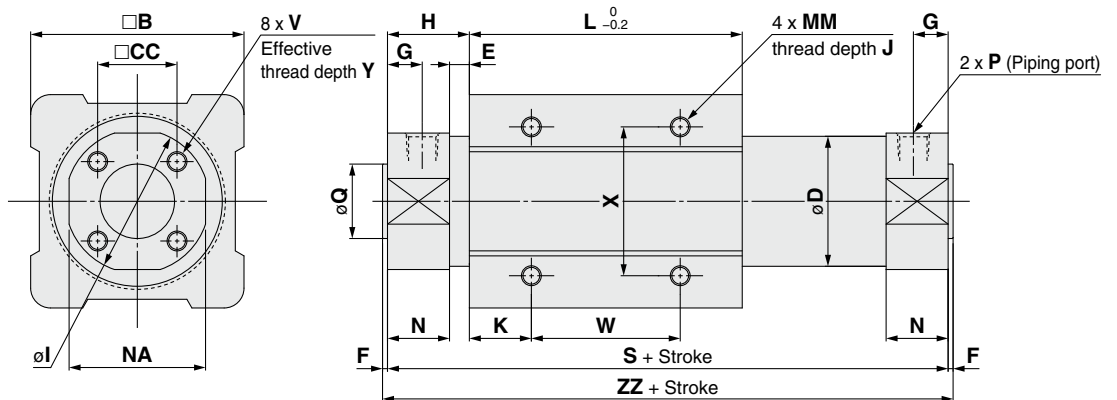

| Model | A | B | C | CC | D | E | F | G | H | I | J | K | L | MM | N | NA | NN | Q | S | T | V |
|--------|----|-----|----|----|------|-----|----|-----|------|------|-----|----|-----|-----------|------|----|-----------|-----------------------------|-----|-----|-----------|
| CY3B6 | 4 | 17 | 8 | — | 7.6 | 4 | 8 | 5 | 13.5 | 11.9 | 4.5 | 5 | 35 | M3 x 0.5 | 9.5 | 10 | M6 x 1 | — | 62 | 6.5 | — |
| CY3B10 | 4 | 25 | 14 | — | 12 | 1.5 | 9 | 5 | 12.5 | 16.9 | 4.5 | 4 | 38 | M3 x 0.5 | 11 | 14 | M10 x 1 | — | 63 | 7.5 | — |
| CY3B15 | 4 | 35 | 14 | — | 16.6 | 2 | 10 | 5.5 | 13 | 19.9 | 6 | 11 | 57 | M4 x 0.7 | 11 | 17 | M10 x 1 | — | 83 | 8 | — |
| CY3B20 | 8 | 36 | 26 | — | 21.6 | 2 | 13 | 7.5 | 20 | 27.9 | 6 | 8 | 66 | M4 x 0.7 | 18 | 24 | M20 x 1.5 | — | 106 | 10 | — |
| CY3B25 | 8 | 46 | 32 | — | 26.4 | 2 | 13 | 7.5 | 20.5 | 33.4 | 8 | 10 | 70 | M5 x 0.8 | 18.5 | 30 | M26 x 1.5 | — | 111 | 10 | — |
| CY3B32 | 8 | 60 | 32 | — | 33.6 | 2 | 16 | 8 | 22 | 39.9 | 8 | 15 | 80 | M6 x 1 | 20 | 36 | M26 x 1.5 | — | 124 | 13 | — |
| CY3B40 | 10 | 70 | 41 | — | 41.6 | 3 | 16 | 11 | 29 | 49.9 | 10 | 16 | 92 | M6 x 1 | 26 | 46 | M32 x 2 | — | 150 | 13 | — |
| CY3B50 | — | 86 | — | 32 | 52.4 | 8 | 2 | 14 | 33 | 58.2 | 12 | 25 | 110 | M8 x 1.25 | 25 | 55 | — | 30 ^{-0.007/-0.037} | 176 | — | M8 x 1.25 |
| CY3B63 | — | 100 | — | 38 | 65.4 | 8 | 2 | 14 | 33 | 72.2 | 12 | 26 | 122 | M8 x 1.25 | 25 | 69 | — | 32 ^{-0.007/-0.043} | 188 | — | M10 x 1.5 |

| Model | W | X | Y | ZZ | P (Piping port) | | |
|--------|----|----|----|-----|-----------------|--------|------|
| | | | | | Nil | TN | TF |
| CY3B6 | 25 | 10 | — | 78 | M3 x 0.5 | — | — |
| CY3B10 | 30 | 16 | — | 81 | M5 x 0.8 | — | — |
| CY3B15 | 35 | 19 | — | 103 | M5 x 0.8 | — | — |
| CY3B20 | 50 | 25 | — | 132 | Rc1/8 | NPT1/8 | G1/8 |
| CY3B25 | 50 | 30 | — | 137 | Rc1/8 | NPT1/8 | G1/8 |
| CY3B32 | 50 | 40 | — | 156 | Rc1/8 | NPT1/8 | G1/8 |
| CY3B40 | 60 | 40 | — | 182 | Rc1/4 | NPT1/4 | G1/4 |
| CY3B50 | 60 | 60 | 16 | 180 | Rc1/4 | NPT1/4 | G1/4 |
| CY3B63 | 70 | 70 | 16 | 192 | Rc1/4 | NPT1/4 | G1/4 |

* Mounting nuts can be screwed on only for the effective thread length of the head cover (T dimension). When mounting a cylinder, consider the thickness of flange, etc.

Mounting Nut: Included in the package (2 pcs.)

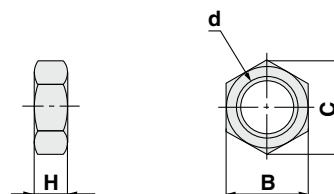

| Part no. | Applicable bore size [mm] | d | H | B | C |
|----------|---------------------------|-----------|----|----|------|
| SNJ-006B | 6 | M6 x 1.0 | 4 | 8 | 9.2 |
| SNJ-016B | 10, 15 | M10 x 1.0 | 4 | 14 | 16.2 |
| SN-020B | 20 | M20 x 1.5 | 8 | 26 | 30 |
| SN-032B | 25, 32 | M26 x 1.5 | 8 | 32 | 37 |
| SN-040B | 40 | M32 x 2.0 | 10 | 41 | 47.3 |

* Mounting nuts are not available for $\phi 50$ and $\phi 63$.

CY3B Series

Made to Order: Individual Specifications 1

Please contact SMC for detailed dimensions, specifications, and lead times.



Applicable Series

| No. | Symbol | Specifications/Description | Bore size [mm] |
|-----|--------|---|----------------|
| 1 | -X116 | Hydro specifications | ø25 to ø63 |
| 2 | -X132 | Air supply port relocated in axial direction | ø6 to ø63 |
| 3 | -X160 | High speed specifications | ø20 to ø63 |
| 4 | -X168 | Helical insert thread specifications | ø20 to ø63 |
| 5 | -X206 | Added mounting tap positions for slider | ø6 to ø63 |
| 6 | -X210 | Non-lubricated exterior specifications | ø6 to ø63 |
| 7 | -X322 | Outside of cylinder tube with hard chrome plated | ø15 to ø63 |
| 8 | -X324 | Non-lubricated exterior specifications (with dust seal) | ø10 to ø63 |

1 Hydro Specifications

Symbol
-X116

This type is applicable for precision constant speed feed, intermediate stop and skip feed.

CY3B Bore size Port thread type - Stroke Z - X116

Hydro specifications ●

Specifications

| | |
|----------------------|----------------|
| Applicable bore size | ø25 to ø63 |
| Fluid | Turbine oil |
| Piston speed | 15 to 300 mm/s |

* The applicable strokes and dimensions are the same as those of the standard product.

2 Air Supply Port Relocated in Axial Direction

Symbol
-X132

CY3B Bore size Port thread type - Stroke Z - X132

Air supply port relocated in axial direction ●

The air supply port has been changed to an axial position on the head cover.

Specifications

| | |
|----------------------|-----------|
| Applicable bore size | ø6 to ø63 |
|----------------------|-----------|

* The applicable strokes are the same as those of the standard product.

* All dimensions excluding the changed parts are the same as those of the standard product.

Dimensions (Dimensions other than those shown below are the same as those of the standard type.)

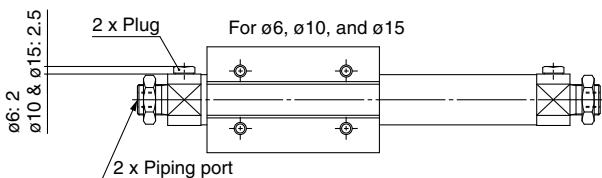

* The port thread size is the same as that of the standard product.

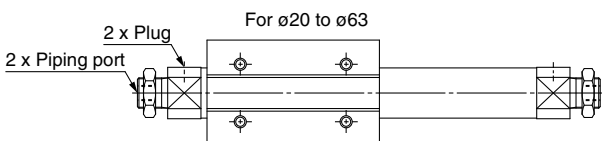

* The port thread size is the same as that of the standard product.

3 High Speed Specifications Symbol
-X160

CY3B Bore size Port thread type – Stroke Z – X160

High speed specifications

This makes a high speed piston drive of 1500 mm/s possible (without load), but it is not applicable for all conditions. Contact SMC for the operating conditions, etc.

Specifications

| | |
|-----------------------------|------------|
| Applicable bore size | ø20 to ø63 |
|-----------------------------|------------|

- * When operating this cylinder at a speed which exceeds the range of the standard product (Max. 500 mm/s), be sure to install a shock absorber, etc.
- * The piston speed may vary depending on the operating conditions. For details, contact SMC or your nearest sales representative.
- * When operated continuously, the speed is likely to decrease over time due to decreased sliding part lubrication, wear of the sliding parts, and environmental factors, so be sure to re-grease the product regularly.
- * The applicable strokes and dimensions are the same as those of the standard product.

4 Helical Insert Thread Specifications Symbol
-X168

CY3B Bore size Port thread type – Stroke Z – X168

Helical insert thread specifications

A product with a helical insert thread that allows for increased mounting screw strength

Specifications

| | |
|-----------------------------|------------|
| Applicable bore size | ø20 to ø63 |
|-----------------------------|------------|

- * The applicable strokes and dimensions are the same as those of the standard product.

5 Added Mounting Tap Positions for Slider Symbol
-X206

CY3B Bore size Port thread type – Stroke Z – X206

Added mounting tap positions for slider

Mounting taps have been added on the surface opposite the standard positions.

Specifications

| | |
|-----------------------------|-----------|
| Applicable bore size | ø6 to ø63 |
|-----------------------------|-----------|

- * The applicable strokes are the same as those of the standard product.
- * All dimensions excluding the changed parts are the same as those of the standard product.

Dimensions (Dimensions other than those shown below are the same as those of the standard type.)

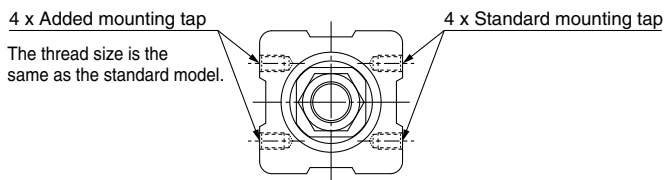

6 Non-lubricated Exterior Specifications Symbol
-X210

CY3B Bore size Port thread type – Stroke Z – X210

Non-lubricated exterior specifications

No grease is applied to the external surface of the cylinder. It is recommended to use this type in a special environment where standard product causes lubrication failure. Contact SMC if rust or foreign matter prevention measures are required, as we need to consider such measures on an individual basis.

- * Consider installing a protective cover if the product is used in an environment where foreign matter such as paper powder might be caught in the sliding parts of the cylinder.

Specifications

| | |
|-----------------------------|-----------|
| Applicable bore size | ø6 to ø63 |
|-----------------------------|-----------|

- * The applicable strokes and dimensions are the same as those of the standard product.

Construction

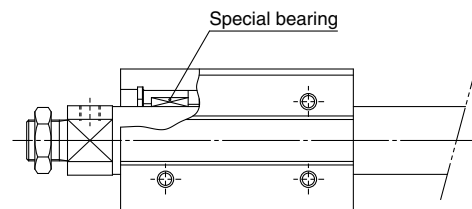

CY3B Series

Made to Order: Individual Specifications 2

Please contact SMC for detailed dimensions, specifications, and lead times.



7 Outside of Cylinder Tube with Hard Chrome Plated Symbol **-X322**

CY3B Bore size Port thread type - Stroke Z - X322

Outside of cylinder tube with hard chrome plated ●

The cylinder tube outer circumference is plated with hard chrome, which further reduces bearing abrasion.

* The maximum stroke is 3500 st, or the maximum stroke for the standard type.

Specifications

| | |
|-----------------------------|------------|
| Applicable bore size | ø15 to ø63 |
|-----------------------------|------------|

* The dimensions are the same as those of the standard product.

Construction

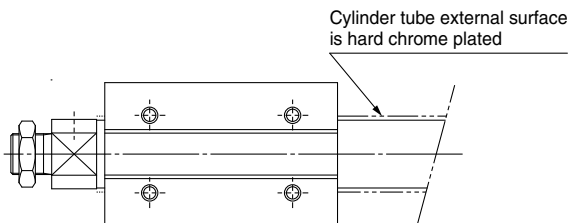

8 Non-lubricated Exterior Specifications (with Dust Seal) Symbol **-X324**

CY3B Bore size Port thread type - Stroke Z - X324

Non-lubricated exterior specifications (with dust seal) ●

No grease is applied to the external surface of the cylinder.

It is recommended to use this type in a special environment where standard product causes lubrication failure.

A felt dust seal is mounted to the external sliding part of the cylinder tube. Contact SMC if rust prevention measures are required, as we need to consider such measures on an individual basis.

* Although a felt dust seal is installed, foreign matter might be caught in the sliding parts of the cylinder. In that instance, consider installing a protective cover.

Specifications

| | |
|-----------------------------|------------|
| Applicable bore size | ø10 to ø63 |
|-----------------------------|------------|

* The applicable strokes and dimensions are the same as those of the standard product.

Construction

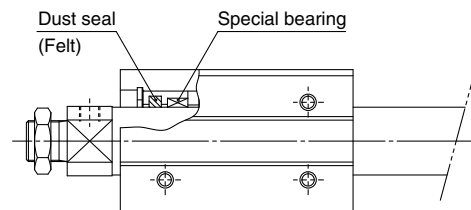



CY3B Series Specific Product Precautions

Be sure to read this before handling the products. Refer to the back cover for safety instructions. For actuator and auto switch precautions, refer to the "Handling Precautions for SMC Products" and the "Operation Manual" on the SMC website: <https://www.smcworld.com>

Handling

Warning

- Pay attention to the space between the head cover and the body.**
Take sufficient care to avoid getting your hands or fingers caught when the cylinder is operated.
- Do not apply a load to a cylinder which is greater than the allowable value stated in the Model Selection.**
Applying an improper load may cause malfunctions.
- Do not use the cylinder in an environment where the cylinder is exposed to moisture, adhesive foreign matter, dust, or liquid such as water or cutting fluid.**
If the cylinder is used in an environment where the lubrication of the cylinder sliding parts is compromised, please contact SMC.
- When applying grease to the cylinder, use the grease that has already been applied to the product. Refer to page 7 for the grease pack.**

Mounting

Caution

- Take care to avoid nicks or other damage on the outside surface of the cylinder tube.**
This can lead to damage of the wear ring and Lube-retainer, which in turn can cause malfunctions.
- Pay attention to any connections with any other axis.**
As the external slider rotates, pay attention not to obstruct the floating at the time of connection with another axis.
- Do not operate with the magnetic coupling out of position.**
In case the magnetic coupling is out of position, push the external slider back into the correct position by hand at the end of the stroke (or correct the piston slider with air pressure).
- Be sure that both end covers are secured to the mounting surface before operating the cylinder.**
Avoid operation with the external slider secured to the surface.

Mounting

Caution

- Do not apply a lateral load to the external slider.**
When a load is mounted directly to the cylinder, variations in the alignment of each shaft center cannot be assimilated, which results in the generation of a lateral load that can cause malfunctions. (Fig. 1) The cylinder should be operated using a connection method which allows for assimilation of shaft alignment variations and deflection due to the cylinder's self-weight. A drawing of a recommended mounting is shown in Fig. 2.

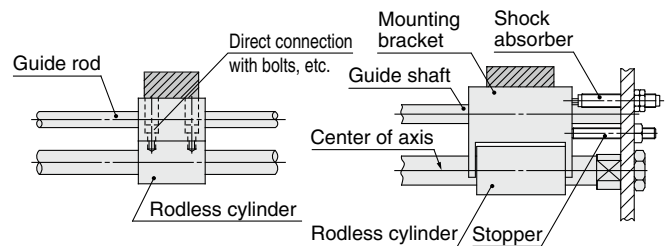

Variations in the load and cylinder shaft alignment cannot be assimilated, resulting in malfunction.

Shaft alignment variations are assimilated by providing clearance for the mounting bracket and cylinder. Moreover, the mounting bracket is extended above the cylinder shaft center, so that the cylinder is not subjected to moment. Provide clearance so that the cylinder is able to operate smoothly within the min. operating pressure range for a full stroke.

Fig. 1. Incorrect mounting

Fig. 2. Recommended mounting

- Careful alignment is necessary when connecting to a load having an external guide mechanism.**
As the stroke becomes longer, variations in the center axis become larger. Consider using a connection method (floating mechanism) that is able to absorb these variations.
- Use caution regarding the allowable load mass when operating in a vertical direction.**
When using the cylinder in the vertical direction, be sure to use it with a load equivalent to or lower than the allowable load weight (reference value on page 3). If a load exceeding the allowable values is applied, the magnetic coupling will be detached and the cylinder will drop. When using the cylinder, check the use conditions (pressure and load).

Disassembly and Maintenance

Warning

- When disassembling the cylinder, be sure to carefully handle it. The adsorption force of the magnet is very strong.**
Handle with caution when removing the external slider and piston slider from the cylinder tube for maintenance, etc. For details, refer to the Operation Manual.

Safety Instructions

These safety instructions are intended to prevent hazardous situations and/or equipment damage. These instructions indicate the level of potential hazard with the labels of “**Caution**,” “**Warning**” or “**Danger**.” They are all important notes for safety and must be followed in addition to International Standards (ISO/IEC)*1), and other safety regulations.

 **Caution:** **Caution** indicates a hazard with a low level of risk which, if not avoided, could result in minor or moderate injury.

 **Warning:** **Warning** indicates a hazard with a medium level of risk which, if not avoided, could result in death or serious injury.

 **Danger :** **Danger** indicates a hazard with a high level of risk which, if not avoided, will result in death or serious injury.

*1) ISO 4414: Pneumatic fluid power – General rules relating to systems.
ISO 4413: Hydraulic fluid power – General rules relating to systems.
IEC 60204-1: Safety of machinery – Electrical equipment of machines.
(Part 1: General requirements)
ISO 10218-1: Manipulating industrial robots – Safety.
etc.

Warning

1. The compatibility of the product is the responsibility of the person who designs the equipment or decides its specifications.

Since the product specified here is used under various operating conditions, its compatibility with specific equipment must be decided by the person who designs the equipment or decides its specifications based on necessary analysis and test results. The expected performance and safety assurance of the equipment will be the responsibility of the person who has determined its compatibility with the product. This person should also continuously review all specifications of the product referring to its latest catalog information, with a view to giving due consideration to any possibility of equipment failure when configuring the equipment.

2. Only personnel with appropriate training should operate machinery and equipment.

The product specified here may become unsafe if handled incorrectly. The assembly, operation and maintenance of machines or equipment including our products must be performed by an operator who is appropriately trained and experienced.

3. Do not service or attempt to remove product and machinery/equipment until safety is confirmed.

1. The inspection and maintenance of machinery/equipment should only be performed after measures to prevent falling or runaway of the driven objects have been confirmed.
2. When the product is to be removed, confirm that the safety measures as mentioned above are implemented and the power from any appropriate source is cut, and read and understand the specific product precautions of all relevant products carefully.
3. Before machinery/equipment is restarted, take measures to prevent unexpected operation and malfunction.

4. Contact SMC beforehand and take special consideration of safety measures if the product is to be used in any of the following conditions.

1. Conditions and environments outside of the given specifications, or use outdoors or in a place exposed to direct sunlight.
2. Installation on equipment in conjunction with atomic energy, railways, air navigation, space, shipping, vehicles, military, medical treatment, combustion and recreation, or equipment in contact with food and beverages, emergency stop circuits, clutch and brake circuits in press applications, safety equipment or other applications unsuitable for the standard specifications described in the product catalog.
3. An application which could have negative effects on people, property, or animals requiring special safety analysis.
4. Use in an interlock circuit, which requires the provision of double interlock for possible failure by using a mechanical protective function, and periodical checks to confirm proper operation.

Caution

1. The product is provided for use in manufacturing industries.

The product herein described is basically provided for peaceful use in manufacturing industries.
If considering using the product in other industries, consult SMC beforehand and exchange specifications or a contract if necessary.
If anything is unclear, contact your nearest sales branch.

Limited warranty and Disclaimer/ Compliance Requirements

The product used is subject to the following “Limited warranty and Disclaimer” and “Compliance Requirements”.

Read and accept them before using the product.

Limited warranty and Disclaimer

1. The warranty period of the product is 1 year in service or 1.5 years after the product is delivered, whichever is first.*2)
Also, the product may have specified durability, running distance or replacement parts. Please consult your nearest sales branch.
2. For any failure or damage reported within the warranty period which is clearly our responsibility, a replacement product or necessary parts will be provided.
This limited warranty applies only to our product independently, and not to any other damage incurred due to the failure of the product.
3. Prior to using SMC products, please read and understand the warranty terms and disclaimers noted in the specified catalog for the particular products.

*2) Vacuum pads are excluded from this 1 year warranty.

A vacuum pad is a consumable part, so it is warranted for a year after it is delivered.
Also, even within the warranty period, the wear of a product due to the use of the vacuum pad or failure due to the deterioration of rubber material are not covered by the limited warranty.

Compliance Requirements

1. The use of SMC products with production equipment for the manufacture of weapons of mass destruction (WMD) or any other weapon is strictly prohibited.
2. The exports of SMC products or technology from one country to another are governed by the relevant security laws and regulations of the countries involved in the transaction. Prior to the shipment of a SMC product to another country, assure that all local rules governing that export are known and followed.

Caution

SMC products are not intended for use as instruments for legal metrology.

Measurement instruments that SMC manufactures or sells have not been qualified by type approval tests relevant to the metrology (measurement) laws of each country. Therefore, SMC products cannot be used for business or certification ordained by the metrology (measurement) laws of each country.

Safety Instructions

Be sure to read the “Handling Precautions for SMC Products” (M-E03-3) and “Operation Manual” before use.

SMC Corporation

Akihabara UDX 15F,
4-14-1, Sotokanda, Chiyoda-ku, Tokyo 101-0021, JAPAN
Phone: 03-5207-8249 Fax: 03-5298-5362
<https://www.smcworld.com>
© 2023 SMC Corporation All Rights Reserved

Specifications are subject to change without prior notice and any obligation on the part of the manufacturer.

D-G